

mooov8™
Health, Mobility, Adventure

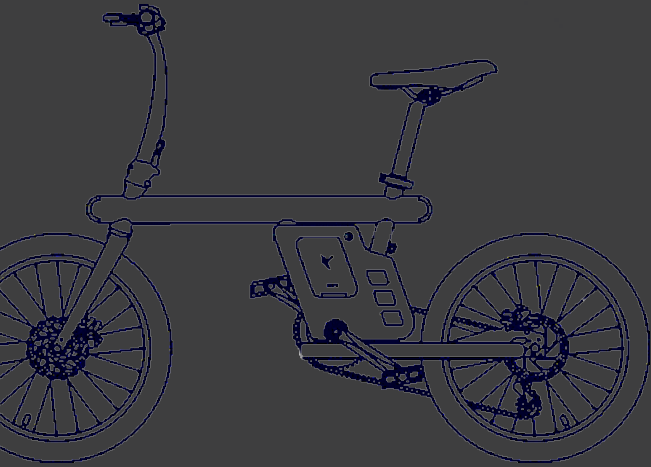

User Manual

Dear Esteemed Buyer,

Thanks for purchasing the Moov8:X. This bike is an electric pedal assist bike (EPAB or Pedalecs). It is equipped with pedals and a power-assisted electric motor, which can be driven by both manpower and with the assistance of electric power.

Travelling is an everyday necessity and adopting an active means of transportation like an electric bike goes a long way to not only helping people get fit and healthy but also lowering their risk of illness, improving air quality and reducing congestion.

Electric bikes can help conserve our environment in a number of ways:

- A zero-emission e-bike is a pollution-free and sustainable mode of transport.
- Bikes, scooters, and personal mobility vehicles reduce the need to build, service and dispose of cars.
- Less cars means less space required for roadways, leaving more space for residential zones, parks and recreation areas.

For your safety please ride with caution, wear a helmet and protective gear, and follow the local traffic rules. Please read the manual carefully, check your bike before riding, and practice before riding on the road.

Have a pleasant ride!



Move out with Moov8

X Diagram

- Included in the box:
- Manual
 - Charger
 - Tool kit

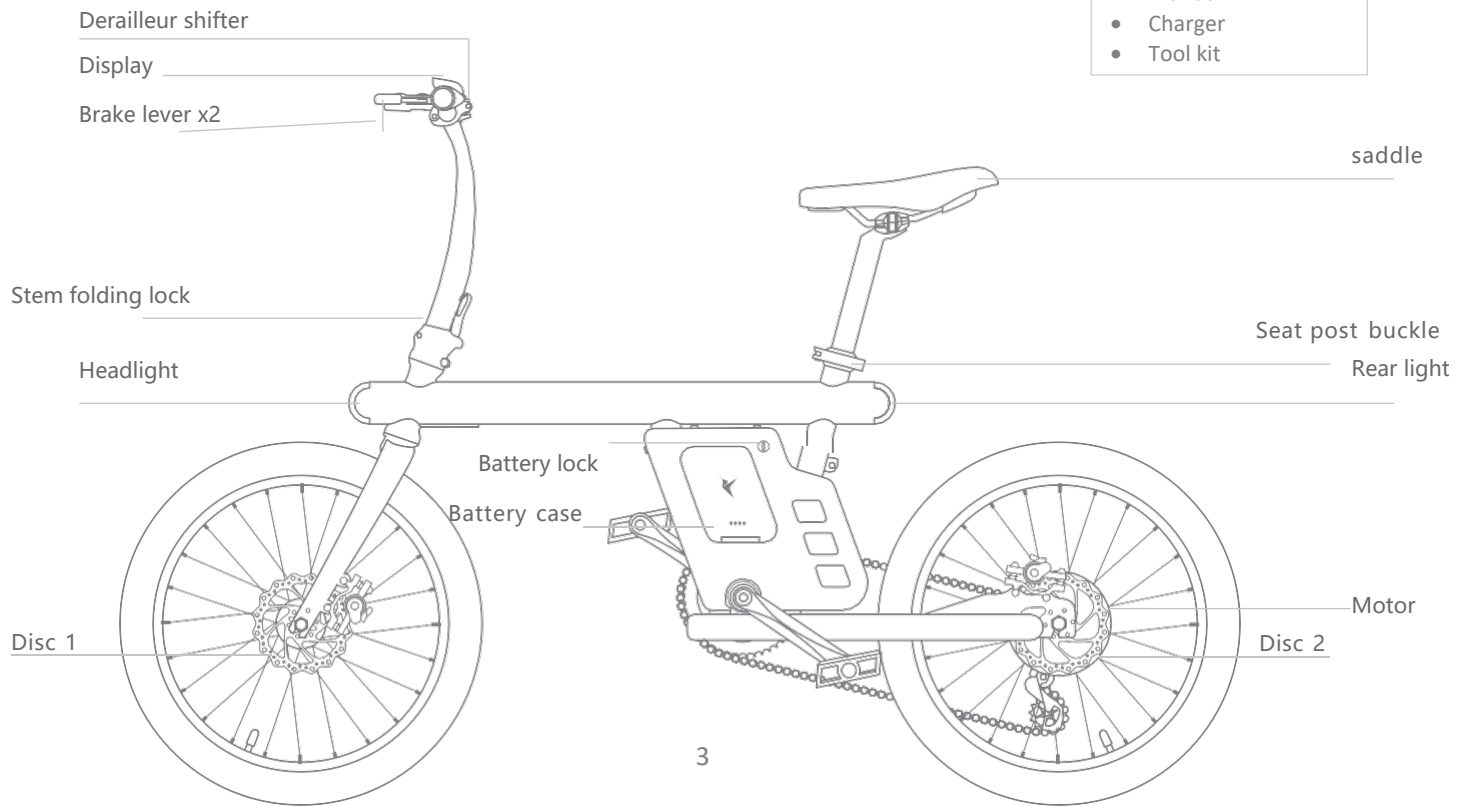

Assembly

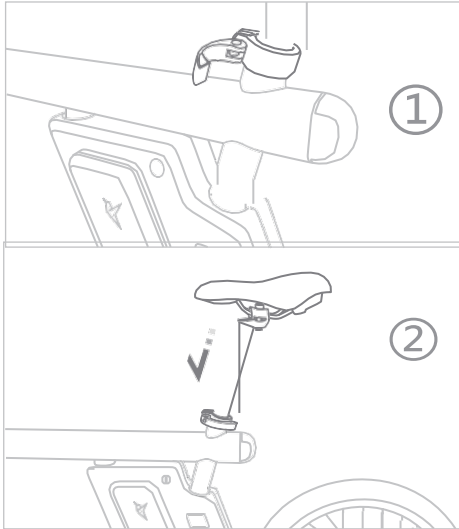

STEP 1. Saddle assemble

Open seat post buckle picture 1 & 2 insert seat post, adjust seat height and direction, and lock seat post buckle 1 & 2.

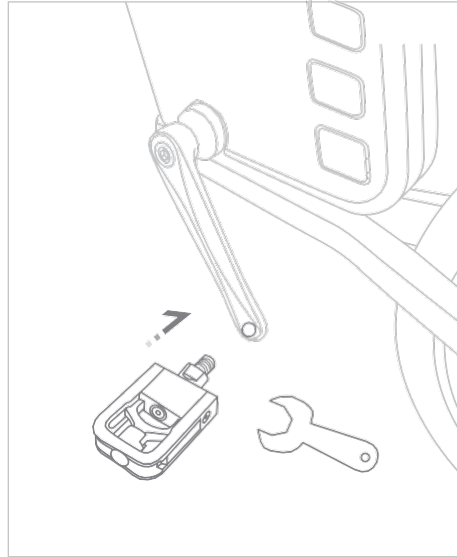

STEP 2. Pedal assemble

Take the pedal and tools from packing carton, tighten pedal and lock with wrench.

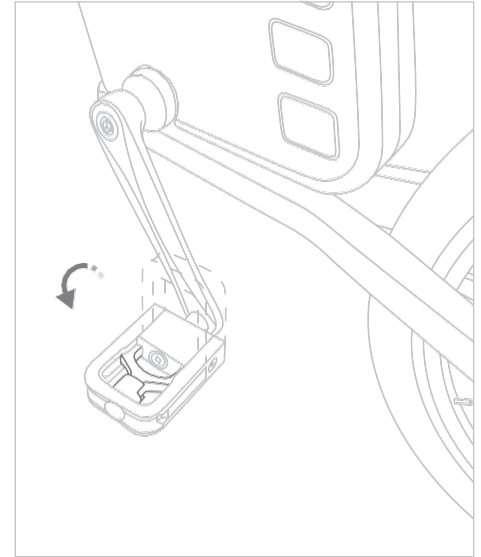

Pedal folding& unfolding

Push the pedal in horizontal and turn 90° to fold or turn pedal to horizontal to unfold.

Assembly

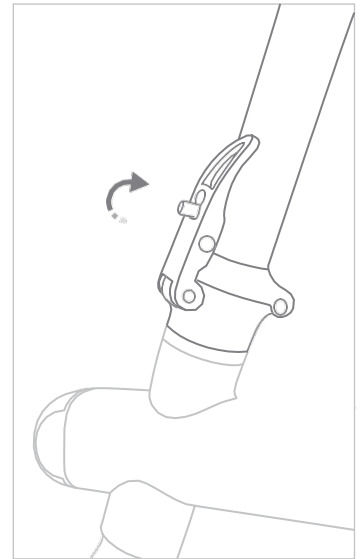
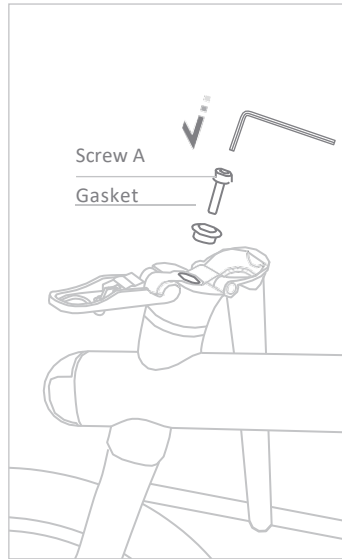
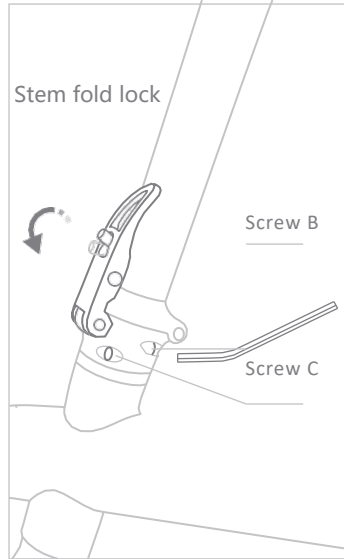

STEP 3. Stem assemble

① Tear off sticker on the stem and screw out bolt with Allen wrench.

② Set head tube (unfolded) in the frame, and lock screw B and C, unlock the stem folding lock and fold stem.

③ Set the Gasket and screw A into stem, and lock by Allen wrench.

④ Unfold the handlebars and lock the folding lock.

Assembly

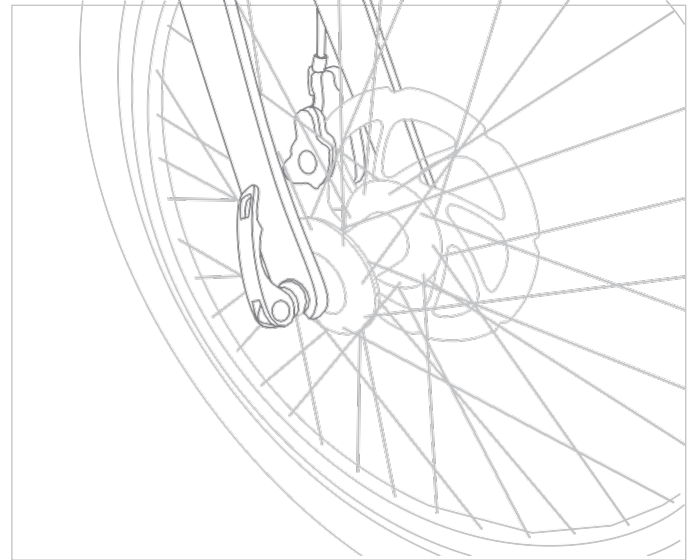
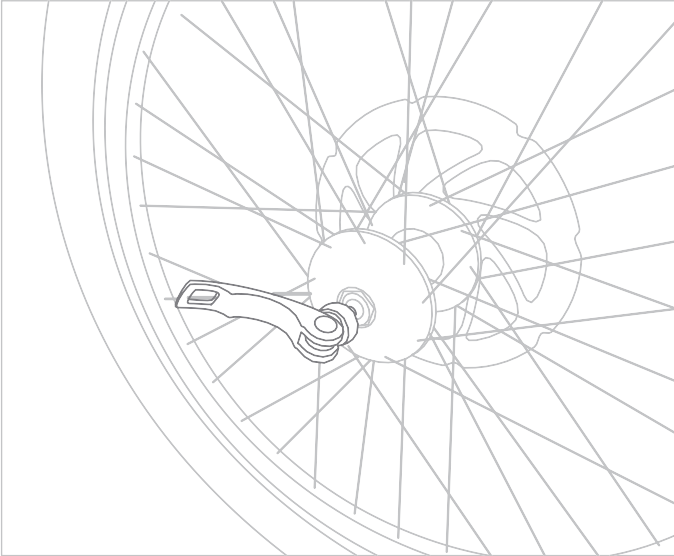

STEP 4. installing front wheel

Loosen the quick release lever and insert into the fork dropouts and tighten the quick release level.

Battery

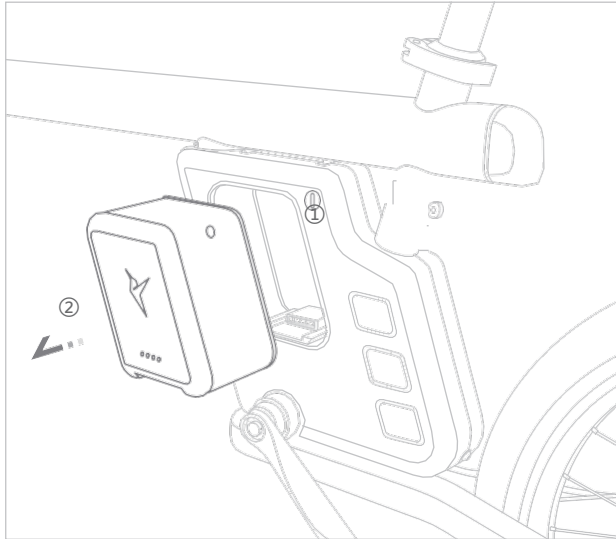

- Removing battery

- ① Turn the key switch with one hand
- ② pulling out the battery with your other hand

- Assembling battery

Push the battery into slot.

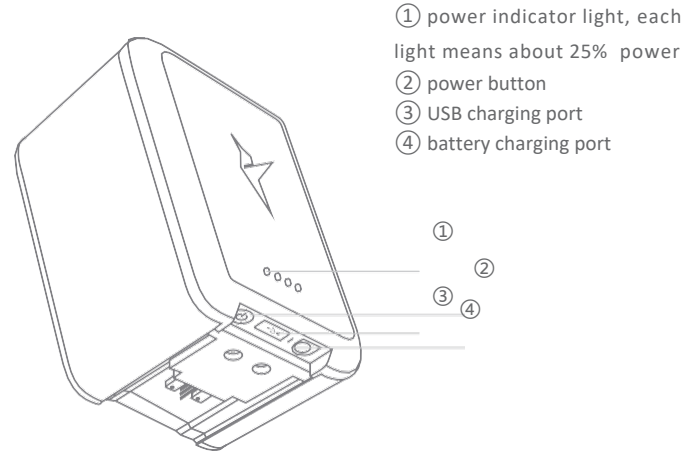

Precautions for battery use

- Please fully charge the battery when charging for the first time.
- When the battery is not in use for a long time, take out and charge at least once a month.
- Try not to exhaust the battery completely during the ride. Please charge the battery when one of the LED battery indicators is left.
- Waterproof note: the battery is not waterproof, please do not use the bike in rain or water for long time.

Controls



- **power on/off**
Press and hold power button to switch on and switch off.
- **up/down mode**
Press “+” up or “-” down button to increase or decrease the Peddle Assist level 1-5
- **light on/off**
Press and hold “+” up button for 3 second can turn on/off the light
- **walking assist function**
Press and hold “-” down button for 3 second to activate walking assist. As per Australian law max. 6km/hour speed allowed.
- **mode**
Press mode button to see various parameters like avg. speed, max. speed, trip time etc.

Routine Maintenance

Frequency	Component	Lubricant	How to Lubricate
Weekly	Chain Derailleur	Chain Lube or Light Oil	Brush on or Squirt
	Pulleys	Chain Lube or Light Oil	Brush on or Squirt
	Derailleurs	Oil	Oil Can
	Brake Calipers Brake Levers	Oil Oil	3 drops from oil can 2 drops from oil can
Monthly	Shift Levers	Lithium Based Grease	Disassemble
Every Six Months	Freewheel	Oil	2 squirts from oil can
	Brake Cables	Lithium Based Grease	Disassemble
Yearly	Bottom Bracket	Lithium Based Grease	Disassemble
	Pedals	Lithium Based Grease	Disassemble
	Derailleur Cables	Lithium Based Grease	Disassemble
	Wheel Bearings	Lithium Based Grease	Disassemble
	Headset Seat Post	Lithium Based Grease Lithium Based Grease	Disassemble Disassemble

Note: The frequency of maintenance should increase with use in wet or dusty conditions. Do not over lubricate – remove excess lubricant to prevent dirt build up. Never use a degreaser to lubricate your chain.

Service Checklist

Frequency	Task
Before every ride	Be sure batteries are fully charged Check tire pressure Check brake operation Check wheels for loose spokes
	After every ride
Weekly	Lubrication
Monthly	Inspect wires / Inspect connectors Check derailleur adjustment/Check brake adjustment Check brake and gear cable adjustment Check tire wear and pressure / Check wheels are true and spokes tight Check hub, head set and crank bearings for looseness Check pedals are tight / Check handlebars and stem are tight Check seat and seat post are tight and comfortably adjusted Check frame and fork for trueness Lubrication Perform safety check
	Every six months
Yearly	Lubrication

Battery charging and maintenance:

A well-maintained battery can perform well even after many kilometers of riding.

Please keep the battery 15 °C to 40 °C when the condition of charging. Do not store below/above - 20 °C ~ 50 °C. Do not store or charge the battery at temperatures outside the stated limits.

Please turn off the power and recharge the battery when the battery power indicator shows a low battery. Avoid draining the battery completely; it will seriously affect the battery performance and life. Please turn off the ebike before charging.

At the time of charging first connect the charger to the battery then the charger points to the power unit before turning on the power switch. After the charge is completed; switch off the power switch; disconnect the charger plug and then remove the charger from the battery.

Please use the original charger, pay attention to the battery type, and the applicable voltage of the charger. Do not mix chargers between bikes. When charging, the indicator light is red, and turns green when fully charged. When the battery is full please unplug the charging head.

Please cover the charging point with the rubber cap after charging, otherwise it may cause battery damage.

Typically, a fully charged battery should retain charge for 120-180 days in Standby Mode. Remember to charge the battery at least once every three months. Completely draining the battery outside this range may cause permanent damage to the battery.

It is strictly forbidden to place the battery in acid and alkaline liquid, keep away from a source of heat and do not damage or disassemble the battery. Do not insert metal objects into the charging port to avoid short-circuit.

If the battery or charging is abnormal, please contact the customer service or sales staff immediately.

Warning

When riding any ebike, care must be taken to avoid personal injury or damage to the ebike. Damage to the ebike may cause loss of power and affect the performance of the product. Please note the follow before using the ebike:

- √ Check if all parts of the Moov8 – M1 are well installed without damage.
- √ Check the brakes operate effectively.
- √ Check that the folding mechanism is locked.
- √ Check the battery is charged.
- √ Check that the front and rear lights are all working properly.
- √ Check the tyre pressure is appropriate.
- √ Check if all nuts and bolts are tight.
- √ Don't carry heavy objects on the handle bar.
- √ Do not ride in the rain or wet conditions.
- √ Don't rotate the handle violently while driving at high speed.
- √ The M1 is designed for one rider only. Don't carry a child.
- √ Wear a helmet and protective clothing to avoid possible injury.

As with all mechanical components, the e-bike is subject to wear and high stresses. Different materials and components may react to wear or stress fatigue in different ways. If the design life of a component has been exceeded, it may suddenly fail possibly causing injuries to the rider. Any form of crack, scratches or change of colouring in highly stressed areas indicates that the life of the component has been reached and it should be replaced.

Caution:

E-bike maintenance and repair require specific skills and appropriate tools. Do not repair your e-bike or change any of its settings if you have the slightest doubt regarding your ability to correctly proceed with such work. Contact your retailer/dealer. Any adjustments or repairs that are not properly done can damage the e-bike and lead to accidents resulting in extensive injuries. Using only genuine replacement parts for safety-critical components.

Cleaning

Always remove the battery when cleaning. Use soapy water or water mixed with a gentle detergent, and then rinse with clean water. Make sure that the controller is not exposed to humidity as it contains electronic components. Do not use a high-pressure washer!

User Responsibility

Your electric bike is safe for the environment. Used parts must be disposed of in appropriate selective sorting recycling bins. Refer to your local laws and regulation regarding battery recycling and/or disposal.

Please note: It is recommended that you inspect the state of the fork, the frame, the suspension and the fasteners on regular basis. The materials and components may be subject to usage and wear.

Specification

Electric/Battery	Mechanical & other specs.
<p>Motor Power: 36V 250W Bafang motor</p> <p>Battery: Samsung Cell 36V 7.8 Ah/8.7 Ah/9.6 Ah/10.5 Ah</p> <p>Range: 40-60 km</p> <p>Charge time: 3-4 hours</p> <p>Max Speed: 25km/hr</p> <p>Sensor: Magnetic hall sensor</p> <p>Drive: 5 Levels Electric Assist</p> <p>Walking Support: yes, 6km/hr.</p> <p>Display: LCD multi-functional</p> <p>Maximum Load: 120 kg</p>	<p>Brake Type: front and rear dual disc brakes</p> <p>Frame: 6061 aircraft aluminium frame</p> <p>Wheel Hub: 20" x 1.95-inch KENDA with reflector</p> <p>Gears: Shimano 7 speed gears</p> <p>Saddle: SR ergonomic comfortable</p> <p>Headset: NECO</p> <p>Chain: KMC, Rust resistant</p> <p>Handlebar: Alloy aluminium</p> <p>Seat post: Alloy aluminium</p> <p>Bell: Yes</p> <p>Fender/Mudguard: Yes</p>

Warranty

Your Moov8-X is covered under a limited 24 months warranty

Limits of warranty:

- √ 24 months warranty for the frame & motor.
- √ 18 months warranty for battery (covers malfunction, but does not cover deterioration of performance)
- √ 12 months for electrical components (controller, charging port, battery charger, digital display)
- √ Other components are considered consumables and are not covered by warranty.
- √ The warranty is for parts replacement only and does not include labor or shipping costs associated with the repair.

The warranty will be null and void if:

- √ damaged to the X was due to exceeding the manufacturers recommended maximum load limits.
- √ water damage, physical damage, incorrect charging or use of charger other than provided by Moov8 for the X.
- √ charging/soring the battery at temperatures outside the stated limits.
- √ Using X for any commercial activities including but not limited to, delivery, renting, sub-leasing, courier etc.
- √ X is not serviced and maintained and service regularly.
- √ damage by man-made causes or accidents.
- √ any modification or change in the product or disassembled or repaired by an unqualified mechanic.
- √ damage caused by, (including but not limited by) assembly, transportation, transit in courier, loading / unloading etc.

Product Statement & Disclaimer

- To ensure your riding safety and a joyful riding experience, we specially request you to comply with the following requirements when using the product.
- Before riding, make sure to read carefully and fully understand the Moov8 - X User Manual.
- Do not let people who have not carefully read and fully understood the Moov8 - X User Manual use your Moov8 - X.
- Strictly comply with the applicable age requirement in your state/ territory to ride an electric bike/personal mobility device.
- Pregnant women or people who are unwell must not use Moov8-X.
- When feeling unwell physically or mentally due to illness or under the influence of medicine or alcohol, do not ride the Moov8 - X.
- Moov8 - X is designed for only one rider, and never try to ride double or more, or ride holding a child.
- Before riding Moov8 – X, make sure that both your physical and mental conditions enable you to freely get on and off the e-bike and control Moov8 - X well, without the help of others.
- Assemble all components correctly and properly in strict accordance with the assembly instructions in Moov8 - X User Manual.
- Improper assembly may cause risks of loss of control, collision or falls. When assembling the X, take care to apply appropriate force, as either screwing too tight or too light may cause damage to the X or malfunctions. Special note: do not conduct assembly or service with the power turned on.
- Do not try to modify or service the Moov8 - X by yourself. Should any problem happen, feel free to contact the retailer/distributor, as this is your most reliable choice.
- Before riding, always make sure that no abnormalities such as loose parts, damage or malfunctions exist.
- Regularly check the tyre pressure. Incorrect tyre pressure may lead to travel instability or damage, or even accidents in extreme cases. Measure the tyre pressure at least once each month and measure again before starting a long-distance ride.
- Should you spot any loose part, damage, abnormality or malfunction during the use of Moov8 – X, stop using it immediately, and carry out troubleshooting and repair timely to avoid dangers.
- Moov8 – X's battery must be stored in environments with a temperature ranging from -20 to 45°C. Do not place Moov8 - X where the temperature is over 50°C. When the ambient temperature falls below -20°C, the battery will enter into a self-locked state, and can't be charged or used.
- Should any leakage or other abnormalities (including breakage, emission of odd smell or smoke, overheating, etc.), stop using the product immediately and prevent the battery from contacting other objects.
- Never try to open or pierce or disassemble the battery, or perform any irrational operations.
- Do not wear high heels or other unsuitable shoes, too loose or ill-fitting clothes for riding Moov8 – X, and always wear specialized protective clothing when riding it.
- Never try to ride Moov8 - X in rainy weathers or on wet roads, as wet and slippery roads may reduce the tyre's resistance and lengthen the X braking distance, and may also lead to loss of control or other accidents incurred by tyre skidding.

- Use a soft cloth to wipe and clean the X body, and never try to flush it with powerful water jets or a high-pressure hose. Do not immerse Moov8 - X in water, or else errors such as uncontrollable malfunctions, abnormalities or accidents may occur.
- Never try to ride Moov8 - X under adverse environmental conditions such as bad weathers, low visibility, poor illumination, etc. Ensure you are physically fit and ready to ride it.
- Nights or other environments with poor light conditions make it hard for riders, drivers and pedestrians to notice each other properly, therefore it's strongly recommended that you do not ride the e-bike under the above-mentioned conditions to avoid potentially serious dangers.
- When riding Moov8 – X, always pay close attention to the changes in the road and surroundings, and always ride cautiously.
- When riding Moov8 – X, always watch out for overhead obstacles.
- During riding, should you encounter an abrupt slope, an uneven road or any other terrain conditions you haven't met before, do not try to risk riding through.
- Do not try to turn abruptly at a high speed or brake suddenly on slippery ground, as these kinds of actions may easily cause the X to skid and render it uncontrollable.
- Ride Moov8 – X on authorized paths and lanes as applicable in your state/territory and strictly abide by traffic rules and other related regulations. When approaching or passing a crossroad, a motor vehicle lane etc., slow down and take care to avoid the pedestrians, and watch out for dangerous behaviors by passing vehicles and people that may pose a threat to your safety.

- While riding, always pay close attention to nearby vehicles, pedestrians, potholes, sewer covers, railroads, expansion joints, construction areas on the road or sidewalk, debris or other obstacles that may pose a threat to your own and others' personal or property safety.
- Never attend phone calls or do any other things that may distract yourself.
- When riding Moov8 – X, do not try to put your hand on another vehicle and get yourself dragged along. And avoid inappropriate behaviors like performing stunts or X-sports, etc.
- When you need to ride Moov8 – X to a remote area, do not go alone. Even if you have partners on your journey, you still have to prepare yourselves well for potential risks.
- Moov8 – X is a personal travel tool made for short journeys, and shall not be used for any other purposes such as goods delivery, etc.
- Data and Parameters of Moov8 – X may vary with different models, and they are subject to change without prior notice.
- AS A CUSTOMER/USER YOU ARE AWARE OF THE RISKS, DANGERS AND HAZARDS ASSOCIATED WITH RIDING THE ELECTRIC BIKES/PERSONAL MOBILITY DEVICES. YOU FULLY UNDERSTAND, ACCEPT AND FULLY ASSUME ALL SUCH RISKS, DANGERS AND HAZARDS AND THE POSSIBILITY OF PERSONAL OR THIRD- PARTY INJURY, DEATH, PROPERTY DAMAGE OR LOSS RESULTING THEREFROM. Please read the manual carefully and fully understand every instruction before riding.
- The laws & rules regarding the use of electric bikes/personal mobility devices varies between states/territories. Customer must review these laws before purchasing and abide by their local by-laws and use responsibly. Ride with caution and safety equipment (including helmets and protective gear) should always be worn when riding.

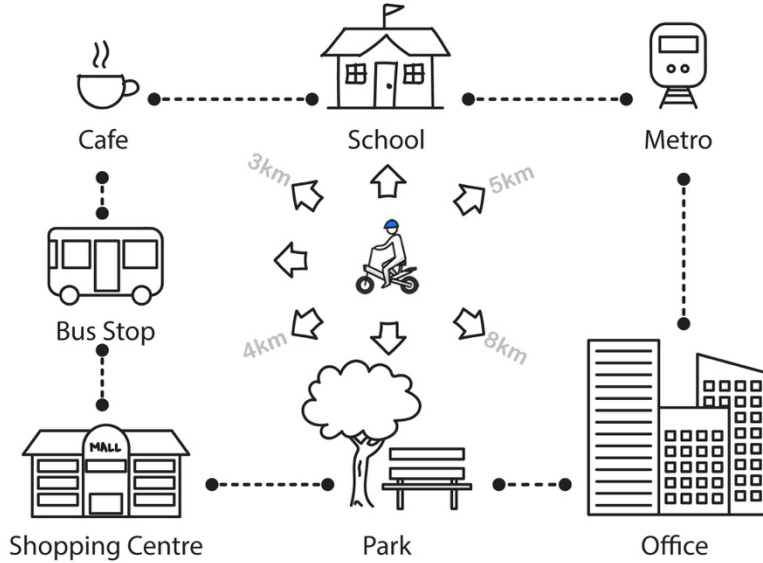

moov8.com.au

Move out with Moov8